



PRODUCER OF PROFESSIONAL REFRIGERATION EQUIPMENT



Pure Energy Equipment

# GARMO RDGA-L4

plug-in

[www.jbg2.com](http://www.jbg2.com)



# GARMO RDGA-L4

plug-in

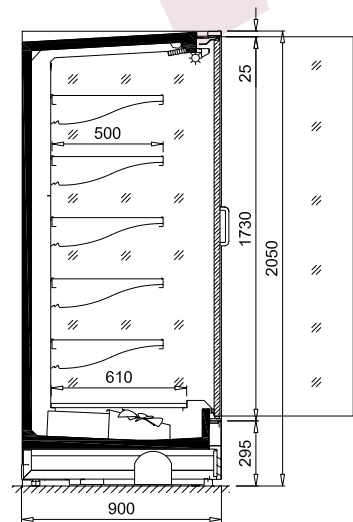

## M1 TEMPERATURE CLASS

modules 1.25 1.875 2.5 3.75

### Standard features:

- plug-in unit
- double glazed doors
- eco-friendly R600a refrigerant
- inverter compressor
- top lighting

- non lamellar condenser (no maintenance)
- very low noise level (<51 dB per 2.5 mod.)
- very low heat emission (1,5 kW per 2.5 mod.)
- low front the same as in the remote version
- additional accessories in standard version (i.e. price holder)
- 4 rows of hanging shelves with adjustable height and inclination (0°, 10°, 20°) + base shelf
- price holders on suspended and base shelves (39 mm)
- transport locks for sheves
- natural defrosting
- no defrost function



#### Standard external colours

- |         |  |         |  |
|---------|--|---------|--|
| RAL9003 |  | RAL1023 |  |
| RAL3000 |  | RAL5010 |  |
| RAL6029 |  | RAL7004 |  |
| RAL7016 |  | RAL9005 |  |

#### Standard screenprinting colours

- Sidewalls:
- |         |  |         |  |
|---------|--|---------|--|
| RAL7037 |  | RAL9005 |  |
|---------|--|---------|--|
- Doors
- |         |  |         |  |
|---------|--|---------|--|
| RAL7037 |  | RAL9005 |  |
|---------|--|---------|--|

# GARMO RDGA-L4

plug-in 3M1-I-R600a-DDO-I3-Z

## Options:

- flow system compatible

### Lighting options:

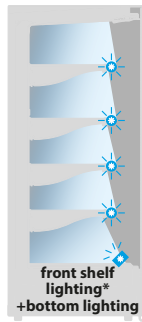
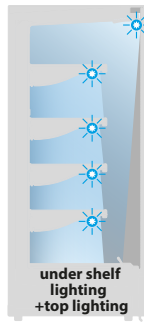
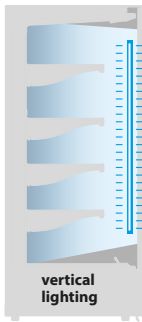

LEDit tube

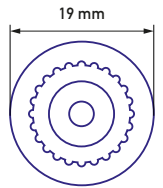

\*requires a special price holder bracket

### MEET THE LEDit FAMILY



Light fitting for refrigeration equipment.



Flat profile lights for refrigeration equipment.



Linear lighting designed for stores, supermarkets and offices.



LEDit profile

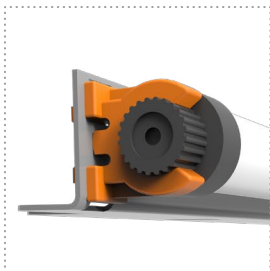
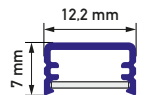

LEDit tube is mounted in rotary holders (patented pending), which ensures the correct positioning of the luminous flux.



LEDit matt or transparent tubes



### Bumper options:

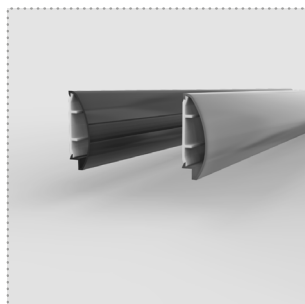
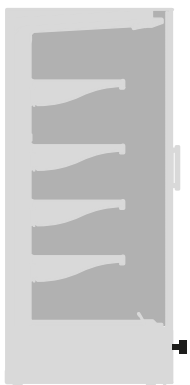

PVC bumper

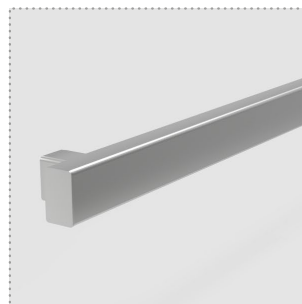

square bumper



tube bumper 2xØ25

# GARMO RDGA-L4

plug-in 3M1-I-R600a-DDO-I3-Z

## Sidewall options:



display sidewall



full square sidewall

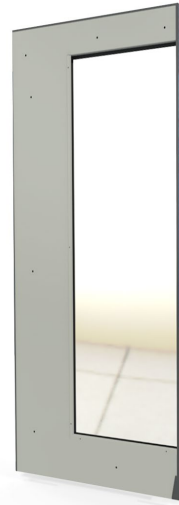

full square sidewall with mirror

## Connection sidewall option:

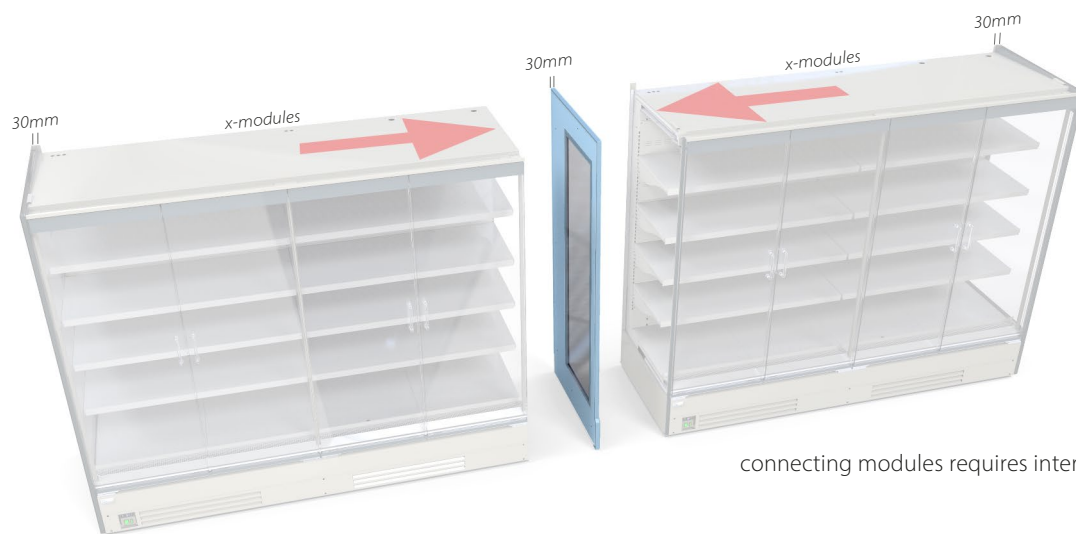

connecting modules requires intermediate sidewall

## High mobile divider:

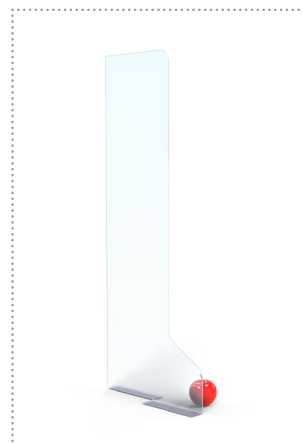
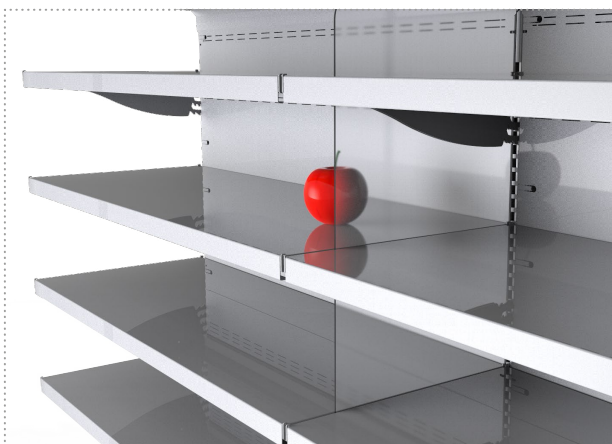

low mobile divider available in various heights

# GARMO RDGA-L4

plug-in 3M1-I-R600a-DDO-I3-Z

## Door options:

### HV - High Vision door system

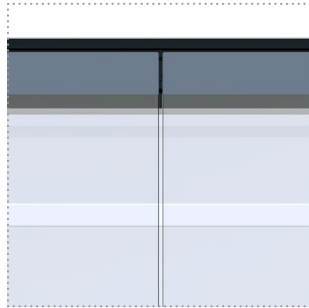
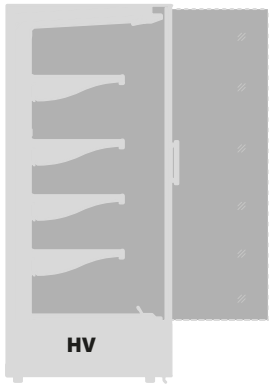

### High Vision

Highly transparent elements significantly improve the visibility and multiply the spectacular effect. Precise fitting eliminates the requirement for rubber profiles and allows maintaining good parameters of equipment performance at the same time.

### DDO - Double doors open

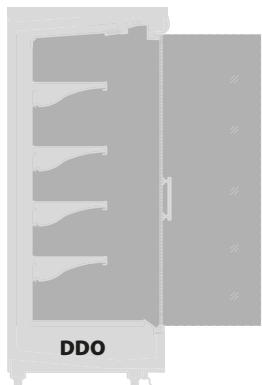

DDO+ transparent frames



Double Doors Open



DDO+ transparent



Double Doors Open

Top

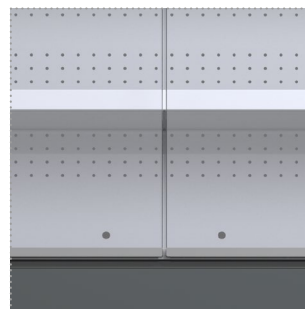

DDO+ transparent

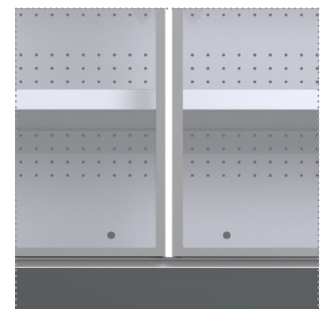

Double Doors Open

Bottom

# GARMO RDGA-L4

plug-in 3M1-I-R600a-DDO-I3-Z

## Handle options:



transparent handle



C profile handle



anodized aluminium handle

## Exposition options:

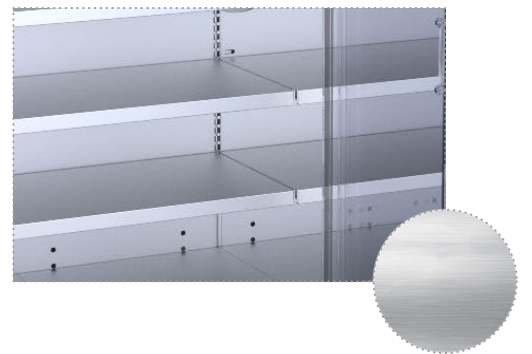

Stainless steel display surface (X5CrNi18-10)

## Evaporator coating options:

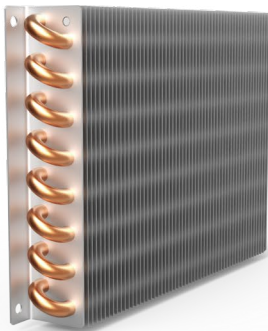

Standard



Epoxy coating



Electrophoretic coating

# GARMO RDGA-L4

plug-in 3M1-I-R600a-DDO-I3-Z

## Price holder options:



**DBR** price holder - standard

height - 39 mm standard, (52 mm option)



**LSR** price holder - option

height - 39 mm standard, (30 mm, 52 mm option)



**WLK** price holder bracket with shelf lighting - option

height - 39 mm standard,

available colors



white



black



transp



white



black



transp



RAL 7016



light gray



black

## Perspex shelf riser options:

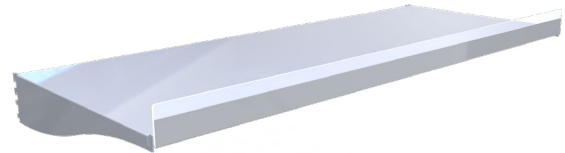
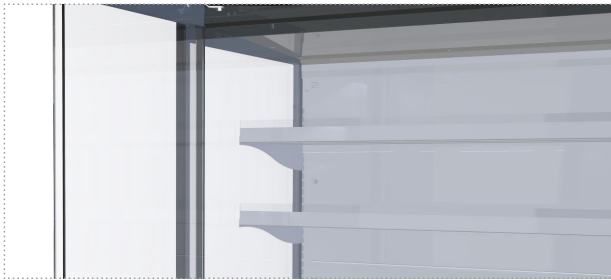

Perspex shelf riser height - 80 mm

## Standard adjustable shelves:



hanging shelves with adjustable height and inclination (0°, 10°, 20°)

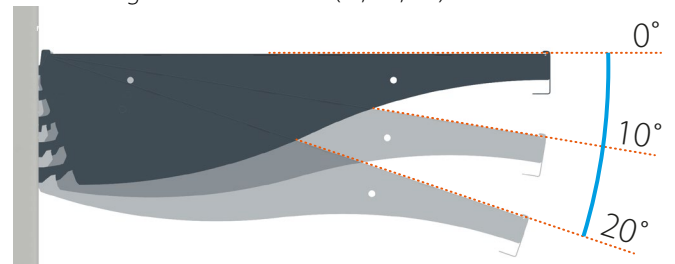

## Top mirror option:



Additional mirror available  
The mirror is attached directly to the casing

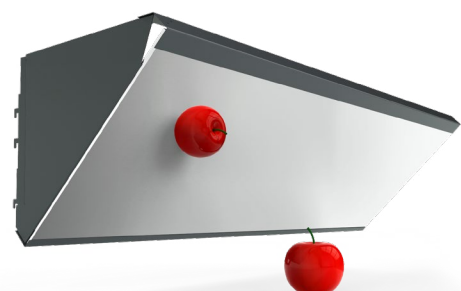

# GARMO RDGA-L4

plug-in 3M1-I-R600a-DDO-I3-Z

## Wire accessories options:



Bottom wire basket 620mm x 600mm x 220mm



Bottom wire grid 620mm x 450mm

## Standard transport lock:

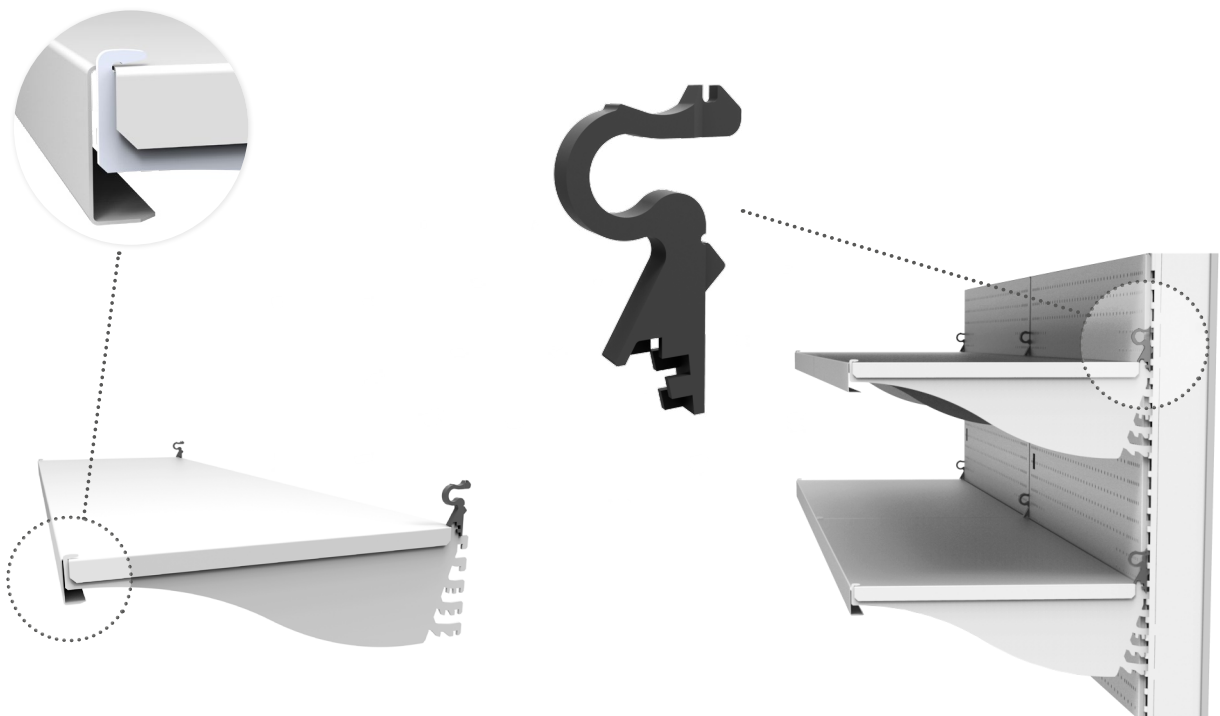

Shelf support transport lock in multidecks.



# GARMO RDGA-L4

plug-in 3M1-I-R600a-DDO-I3-Z

## Calculations:

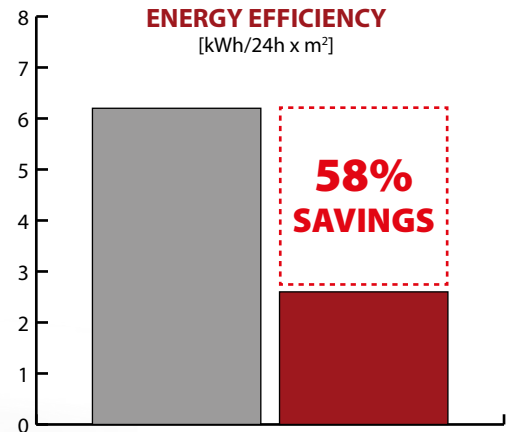

### RDGA-L4

MODEL	1.25	1.875	2.5	3.75
ENERGY CONSUMPTION TEC [kWh/24h]	4,2	6,8	8,3	12,5
TOTAL DISPLAY AREA TDA [m <sup>2</sup> ]	1,58	2,38	3,17	4,75
ENERGY EFFICIENCY EE [kWh/24h x m <sup>2</sup> ]	2,66	2,86	2,62	2,63

Climate class No. 3  
EN ISO 23953-2:2015

Photos, visualization or designs presented in the brochure  
are not a commercial offer of JBG-2

### JBG-2 Sp. z o.o.

ul. Gajowa 5  
43-254 Warszowice

### Office:

E: info@jbg2.com  
T: +48 32 494 00 00

