



Smeva Vision 5000 Serve-over cabinet

Meat, Fish, Deli and Cheese



Specification

Manufactured by Smeva B.V. in the Netherlands, the Vision 5000 serve-over cabinet is designed to maintain the product at the very highest quality and to display to the best advantage for the customer. The design comprises a cold-plate in the base of the cabinet, controlled by an EPR to hold the base temperature just above freezing so the ice remains fluid. The evaporator in the back of the cabinet has a very low air velocity, to reduce the drying of the product to a minimum. In addition for fish and meat products the cabinet can be fitted with a misting system to keep the required level of the humidity within the cabinet.

The solid design ensures a long life, with many Smeva cabinets being used in excess of 15 years from manufacture. We often experience once customers have used Smeva cabinets they are not prepared to accept an alternative.

We are able to offer all the cabinets in a range of finishes, the front panels can be manufactured in stainless steel as shown above or any standard RAL colour finish. Bumpers can be supplied to match cabinet colours as required.

Dimensions

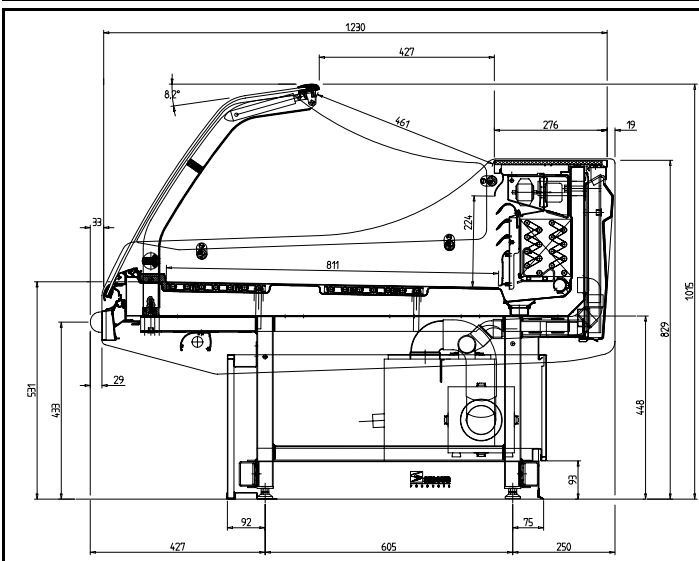

Cabinet Dimensions

Overall height:	1015mm	40"
Overall depth:	1230mm	48.4"
Working bench height:	829mm	32.6"
Working bench depth:	276mm	10.8"
Cabinet lengths:	3000mm	118"
	3500mm	137.8"
	4000mm	157.5"
	4500mm	177"
	5000mm	196.8"
	5500mm	216.5"
Gable end thickness:	30mm	1.2"