

Rev	Description	Date
-----	-------------	------

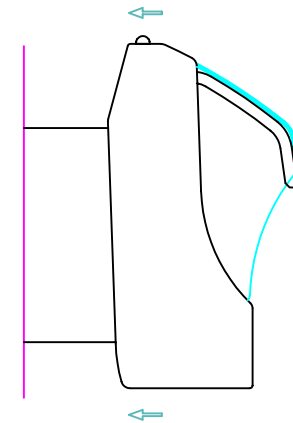
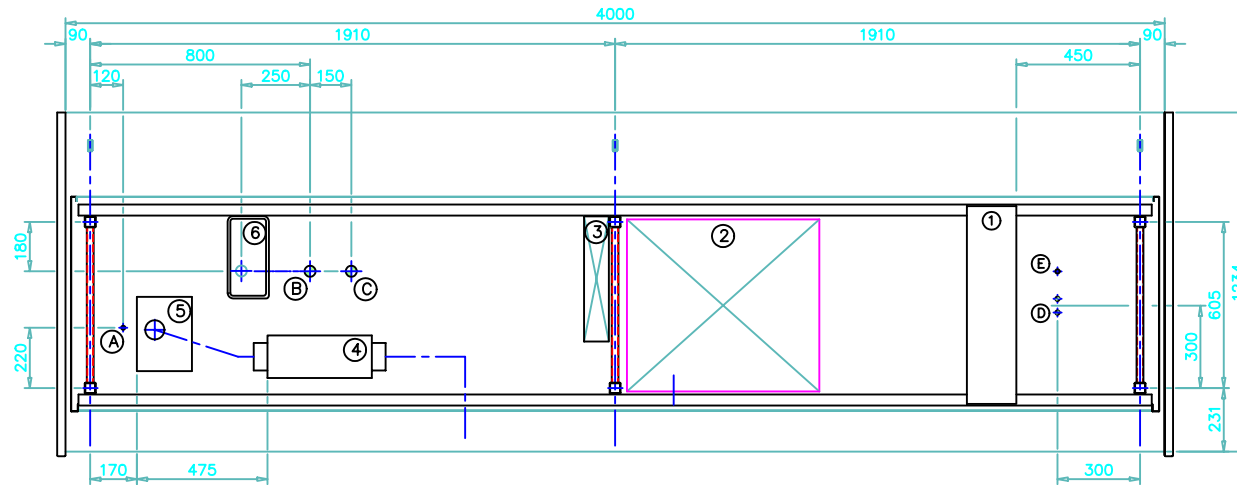

Vision Floorplan Waitrose
L=4000

- Ⓐ Water connection valve (d=15)
- Ⓑ Drain connection humidifier unit (d=40)
- Ⓒ Drain connection (d=40)
- Ⓓ Connectionpoint cooling pipes
- Ⓔ Connectionpoint electricity

- ① Cooling valve panel
- ② Main connection box
- ③ Lighting ballast box
- ④ Filterbox humidifier
- ⑤ Humidifier unit (UTB)
- ⑥ Drip tray humidifier

Title: WAITROSE VISION CABINET – 4000MM

Drawn:

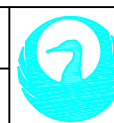

Phoenix Retail Services Ltd

Customer / Store: WAITROSE VARIOUS

Date:

Oakridge House, Wellington Road, Cressex Business Park,
High Wycombe HP12 3PR U.K.
Tel: 01494 472187 Fax: 01494 464904 e-mail: sales@phoenixretail.com