

# SCU 515/535

---

## SERVICE MANUAL

version 01-1999

**©(NL) Copyright**

Deze handleiding is een uitgave van Smeva B.V. Valkenswaard Nederland.

Niets uit deze uitgave mag worden gecopiërd (inclusief vertalingen) als geheel of in gedeelte(n) bijvoorbeeld door Fotocopiëren, Microfilms of gebruik in databanken als in computers, zonder de voorafgaande schriftelijke toestemming van de uitgever.

De handleidingen geven de stand van de techniek weer, op het moment van het ter presse gaan.

Wij behouden ons het recht voor om tussentijdse wijzigingen door te voeren in zowel technische en uitvoerings specificaties.

**©Copyright door Smeva B.V. Nederland. Gedrukt in Nederland.**

**(GB) IMPRINT**

These instructions are published by Smeva B.V. Valkenswaard Nederland.

No reproduction (including translation) is permitted in whole or in part e.g. photocopy, microfilming or storage in electronic data processing equipment, without the express written consent of the publisher.

The operating instructions reflect the current technical specifications at the time of the print.

We reserve the right to change the technical or physical specifications.

**©Copyright by Smeva B.V. Nederland. Printed in The Netherlands.**

**(F) Note de l'éditeur**

Cette notice est une publication de Smeva B.V. Valkenswaard Nederland.

Tous droits réservés. y compris traduction. Toute reproduction, quel soit le type, par exemple photocopies, microfilms ou saisie dans des traitements de texte électronique est soumise à une autorisation préalable écrite de l'éditeur.

Cette notice est conforme à la réglementation en vigueur lors de l'impression. Données techniques et conditionnement soumis à la modifications sans aucun préalable.

**©Copyright by Smeva B.V. Nederland. Imprimé en Hollande.**

**(D) Impressum**

Diese Anleitung ist eine Publikation von Smeva B.V. Valkenswaard Nederland.

Alle Rechte, einschließlich Übersetzung vorbehalten. Reproduktionen jeder Art, z.B. Fotokopie, Mikroverfilmung, oder die Erfassung in elektronische Datenverarbeitungsanlagen, bedürfen der schriftlichen Genehmigung des Herausgebers.

Diese Bedienungsanleitung entspricht dem technischen Stand bei Drucklegung. Änderung in Technik und Ausstattung vorbehalten.

**©Copyright bei Smeva B.V. Nederland. Gedrückt in die Niederlande.**

**CONTENTS**

<b>1 INTRODUCTION .....</b>	<b>3</b>
-----------------------------	----------

<b>2</b>	<b>THE CONTROL PANEL .....</b>	<b>4</b>
<b>3</b>	<b>MAIN FUNCTIONS.....</b>	<b>5</b>
3.1	KEYS .....	5
3.2	INDICATORS.....	7
<b>4</b>	<b>VIEWING AND CHANGING MENUS .....</b>	<b>8</b>
4.1	VIEWING A MENU.....	8
4.2	CHANGING SETTINGS .....	9
<b>5</b>	<b>SETTINGS MENU.....</b>	<b>9</b>
5.1	SELECTING SETTINGS MENU.....	9
5.2	FUNCTIONS WITHIN THE SETTINGS MENU .....	10
<b>6</b>	<b>TYPE MENU .....</b>	<b>10</b>
6.1	SELECT TYPE MENU .....	10
6.2	FUNCTIONS WITHIN THE TYPE MENU .....	11
<b>7</b>	<b>FUNCTION MENU.....</b>	<b>11</b>
7.1	SELECTING FUNCTION MENU.....	11
7.2	FUNCTIONS WITHIN THE FUNCTION MENU .....	12
<b>8</b>	<b>DEFROST MENU .....</b>	<b>15</b>
8.1	SELECTING DEFROST MENU.....	15
8.2	FUNCTIONS WITHIN THE DEFROST MENU.....	15
<b>9</b>	<b>CALIBRATION MENU .....</b>	<b>17</b>
9.1	SELECTING CALIBRATION MENU .....	17
9.2	FUNCTIONS WITHIN THE CALIBRATION MENU .....	17
<b>10</b>	<b>ALARM MENU.....</b>	<b>19</b>
10.1	SELECT ALARM MENU.....	19
10.2	FUNCTIONS WITHIN THE ALARM MENU .....	19
<b>11</b>	<b>OTHER FUNCTIONS .....</b>	<b>20</b>
11.1	MANUAL DEFROSTING.....	20
11.2	ADDITIONAL CONNECTIONS.....	20
<b>12</b>	<b>ENCLOSURES .....</b>	<b>21</b>
	ENCLOSURE 1A: BACK VIEW OF CONTROL.....	21
	ENCLOSURE 1B: REPLACING THE FUSE .....	21
	ENCLOSURE 1C: JUMPER FOR THE END OF A NETWORK.....	22
	ENCLOSURE 1D: TECHNICAL SPECIFICATIONS .....	22
	ENCLOSURE 1E: CALIBRATING THE SENSORS.....	22
	ENCLOSURE 2 : DEFAULT VALUES SCU 515/535 .....	23

## **1 INTRODUCTION**

The SCU 515 and 535 are controls suitable for one (SCU 515) and a maximum of three (SCU 535) cooling sections. It is also possible to operate an additional display shelf or bottom cooling with the temperature control of cooling section 1 or an additional alarm can be used. However, both control panels can of course be used to regulate a cooling or freezing cell. The SCU 515 and

535 are microprocessor controlled. The program has been specially developed to enable the user to check and/or change all the important functions from one central point. These functions (setting the switching off temperatures, air humidifying capacity, date and time) are to be found in the settings menu.

In addition to the settings menu, there are 5 menus in the program: the function menu, the defrost menu, the calibration menu, the alarm menu and the type menu. These menus are intended for the service engineer and are not for the user. They will be dealt with in the following sections.

The electrical diagrams of this control are to be found in the showcase service manuals. They can be requested from Smeva Products, Service After Sales department.

## **2 THE CONTROL PANEL**

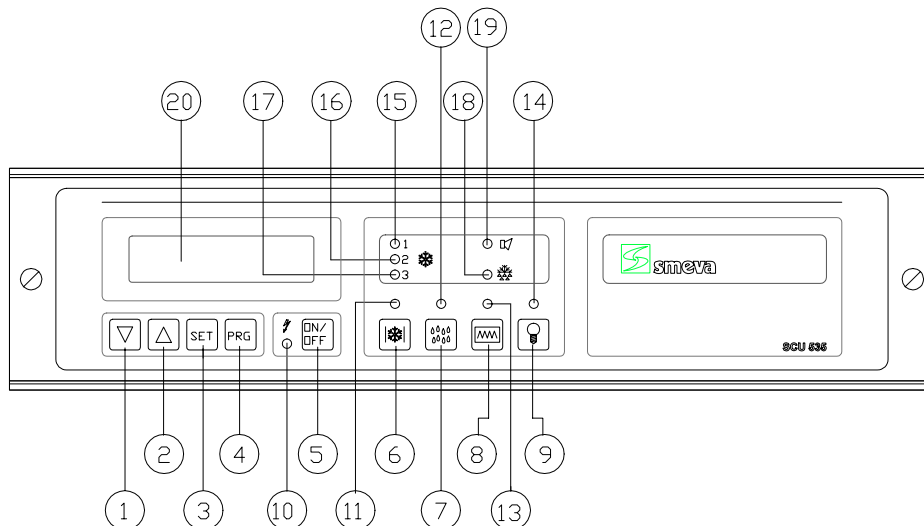

Figure 1: Control panel SCU 535 (=SCU 515, without LEDs 15 and 17)

- 1: "Down" key
- 2: "Up" key
- 3: Set key
- 4: Programming key
- 5: On/off key cooling section 1/3
- 6: Key for additional cooling
- 7: Air humidifying key
- 8: Anti-condensation key
- 9: Lighting key
- 10: LED on/off key cooling
- 11: LED of the additional cooling
- 12: LED of the air humidifier
- 13: LED of the anti-condensation
- 14: LED of the lighting
- 15: LED of top cooling (section 1)
- 16: LED of top cooling (section 2)
- 17: LED of top cooling (section 3)
- 18: Defrost LED
- 19: Alarm LED
- 20: LCD display with backlight

### 3 MAIN FUNCTIONS

#### 3.1 Keys

A function can be switched on by pressing the relevant key. To switch the function off again, press the key once more. All functions are indicated with LEDs. If an LED is lit continuously, this means that the corresponding function is switched on and active. However, if the LED flashes, this means that the function in question is actually switched on, but is overruled internally by another function and thus is not active.

Example: The night offset (automatic switch to a higher night temperature) is switched on if the lighting is switched off. At this moment you can switch the window heating on, but it will not be active. The LED will start to flash. This linking of functions is programmed at the factory.

#### On/off key cooling (key 5):

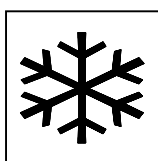

On and off switch for the top cooling and (if present and programmed as such) the additional cooling. Indicated by LED 10. If the top cooling is switched off, all other functions will also be automatically switched off, with the exception of the lighting and the additional cooling (programmed at the factory).

#### Additional cooling (key 6):

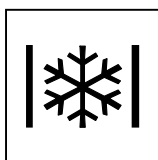

On and off switch for the additional cooling, for example an additional display shelf, bottom cooling, or on and off switch for alarm output. On/off indication by LED 11. The additional cooling is automatically switched off if the lighting is switched off. When the defrost operation switches on (standard factory setting), the extra cooling unit is automatically switched off until the end of the defrost period, whereupon it is automatically switched back on. LED 11 flashes if the function is still on at the control panel, but is switched off internally.

#### Air humidification (key 7):

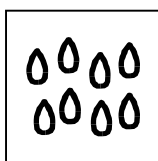

On and off switch for the ultrasonic air humidifier. On/off indication by LED 12. The air humidifier can only operate if the cooling is on and switches off automatically during defrosting (set as standard at the factory). LED 12 flashes if the function is still on at the control panel, but is switched off internally. If an RH sensor is connected, it controls the air humidity percentage.

#### Anti-condensation (key 8):

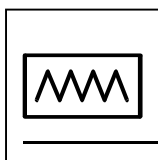

On and off switch for the window, rest section and/or work top heating or nose ventilation to prevent condensation forming. On/off indication by LED 13. The heating can be switched on if the top cooling is switched on and is automatically

switched off when the lighting is switched off (set as standard at the factory). LED 13 flashes if the function is still on at the control panel, but is switched off internally.

**Lighting** (key 9):

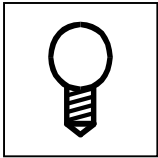

Lighting on and off switch. On/off indication by LED 14.

The control panel is programmed at the factory so that when the lighting is switched off the night offset switches on automatically. This has the effect of controlling the temperature at a higher set-point value, but a number of functions are also switched off automatically while they are actually switched on. In this case the LEDs in question start to flash instead of being lit continuously.

**3.2 Indicators**

**Top cooling** (LED 16 (SCU515) or LEDs 15,16 and 17(SCU535)):

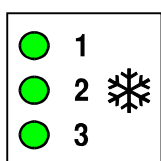

Cooling on/off indicator for the 3 sections of the top cooling. The LEDs light up when cold is requested by the section in question.

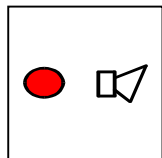
**Alarm (LED 19):**

Alarm indicator, for example when a certain temperature limit is exceeded or when there is a sensor error (however, no settings are preprogrammed as standard at the factory). If additional cooling is not used, if necessary a sound device can be connected so that a signal also sounds. In the case of an alarm the fault is displayed in the function menu (function: last error). The alarm signal, which is triggered by way of the extra function, can be suppressed by pressing the "extra cooling unit" button:

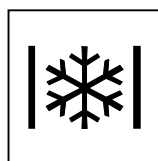
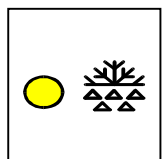
**Defrosting (LED 18):**

Indicator for defrosting activities. The small LED is lit during defrosting and flashes during the fan delay (M30 freezing) or for 10 minutes after defrosting. Defrost periods with corresponding defrost end temperatures are preprogrammed at the factory.

## 4 VIEWING AND CHANGING MENUS

### 4.1 Viewing a menu

The display indicates as standard the actual temperatures of the cooling sections and, if an air humidity sensor is connected, the air humidity of section 1. By pressing a certain key (combination), you can then go from here to another menu. You can then run through the menu with the "UP" or "DOWN" key. The section temperatures are shown again in the display if no key has been pressed for more than 30 seconds or when "PRG" is pressed.

Selecting a certain menu (see appropriate menu for the access combination).

1. Running through menu:

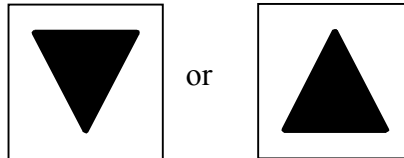

2. Closing menu:



## 4.2 Changing settings

The set values can be changed according to customer requirements. When the setting to be changed is shown on the display, this can be changed by pressing the "SET" key and the "UP" or "DOWN" key at the same time until the required value appears. Another setting can then be changed or you can return to the previous menu by pressing "PRG".

Changing settings:

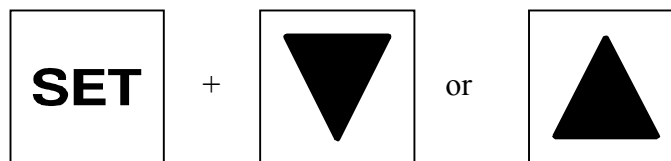

Closing menu:



## 5 SETTINGS MENU

### 5.1 Selecting settings menu

This menu is the only menu that is also accessible to the user; it can be activated with the "PRG" key. The set point of section 1 is immediately visible. You can then go through the whole menu by pressing the "UP" or "DOWN" key. The functions you see here are dealt with in section 5.2.

Activating settings menu:



## 5.2 Functions within the settings menu

### Set point section 1,2,3

Here you can set the set points of cooling section 1 and, if present, the set points of sections 2 and 3 can be set within the temperature range -40 °C...20 °C (depending on the type of cooling furniture). If a "+" symbol flashes to the right of the set point, this means that the night offset has switched on.

- ID. 1: The Masterliner static and the SM 3000 are set at evaporator-temperature. The Vision, the Masterliner dynamic, the Showliner dynamic and static, the SM 5000 and the cooling and freezing cells are set at air temperature. The evaporator temperature is measured by a sensor located in the evaporator. The air temperature is measured by two sensors, one on the air intake side and one on the air expel side of the evaporator and the average of the two temperature measurements is taken.
- ID. 2: The switching off temperature of section 2 and 3 should not be colder than the switching off temperature of section 1 if the cooling device is connected to a stand alone machine.

### Capacity humidifier

Here you can set the capacity of the air humidifier (10%, 20%...and 100%).

- ID. This function is only available on Smeva showcases in which an air humidifier of the type ultrasonic compact has been installed.

### Time

Here you can set the time.

- ID. Mind the summer-/winter-time, set time by hand.

### Date

Here you can set the date.

- ID. Mind a leap-year, set date by hand.

## 6 TYPE MENU

### 6.1 Select type menu

In the type menu you can select a Smeva product, after which all standard set values of the selected product are programmed fully automatically (see appendix 2). The type menu can be selected by pressing the "PRG" key and the **lighting key at the same time**. After 5 seconds the set type of cooling unit appears on the display. You can then go through the menu by pressing the "UP" or "DOWN" key. The functions you see here are dealt with in section 6.2.

Select type menu:

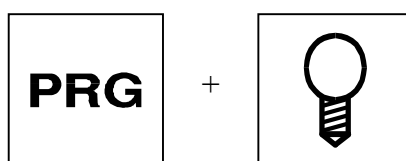

## 6.2 Functions within the type menu

### Model type

With this function you can set the model which is to be regulated by this control. When this setting is used, the corresponding default values are set automatically (see appendix 2).

### Temperature readout

With this function you can select a temperature in degrees Celsius or degrees Fahrenheit.

### Number sections

You can set the number of cooling sections with this function. (Only applies to the SCU 535)

ID. : If for testing purposes the type menu is selected and a different type is set, the set second and third sections disappear. They will then have to be programmed afresh (see section 6.2 for further details).

## 7 FUNCTION MENU

### 7.1 Selecting function menu

The function menu can be selected by pressing the "**PRG**" and "**DOWN**" keys at the same time. "FUNCTIONS MENU" appears on the display after 5 seconds. The menu will be activated by pressing the "**SET**" key. The actual temperature in the evaporator of section 1 appears in the display. You can then go through the menu by pressing the "**UP**" or "**DOWN**" key. The functions you see here are dealt with in section 7.2.

Select function menu:

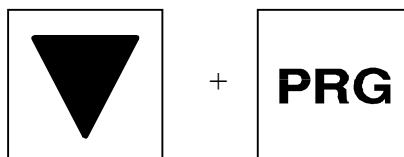

Activate function menu:



## 7.2 Functions within the function menu

### Evaporator temperature 1, 2, 3 (functions 1-3)

These functions display the actual evaporator temperatures of the cooling sections.

### RH sensor (function 5)

This function indicates if there is an air humidity sensor connected (yes) or not (no). If a sensor is connected, the air humidity content is displayed on the bottom right of the display. A black dot to the left of this value indicates that humidification is taking place at that moment.

### Night offset at light off (function 6)

With this function you can set the night offset to come on when the light is switched off (yes) or not (no).

### Moist at cooling (function 7)

This function indicates whether humidification is automatically switched on (yes) or not (no) when the cooling is on.

### Moist at section 1 (function 8)

With this function you can set whether the humidification is automatically switched on (yes) or not (no) by the temperature switch in section 1.

### Moist at defrost (function 9)

With this function you can set whether the humidification is on (yes) or not (no) during defrosting.

### Window heat at cooling (function 10)

With this function you can set whether the window heating is automatically switched on (yes) or not (no) when the cooling is on.

### Window heat at night offset (function 11)

With this function you can set whether the window heating remains switched on (yes) or not (no) when the night offset is on.

### Extra function or alarm (function 12)

Here you can select an additional function, such as an additional display shelf or bottom cooling or an alarm function. If this function is taken an alarm function can be generated via the RS 485 port and interface. For further details about this, see enclosure 1A.

### Extra function at light off (function 13)

With this function you can set whether the additional function remains switched on (yes) or not (no) when the light is switched off.

**Extra function at cooling** (function 14)

With this function you can set whether the additional function is automatically on (yes) or not (no) when the cooling is switched on.

**Extra function at defrost** (function 15)

With this function you can set whether the additional function is on (yes) or not (no) during defrosting.

**Fans at section 1** (function 85, walk-in freezer M30 only)

With this function, it is possible to set whether the fans do (yes) or do not (no) stay on during defrost.

**Extra function at section 1** (function 16)

With this function you can set whether the additional function is automatically switched on (yes) or not (no) by the temperature switch in section 1.

**Hysteresis 1,2,3** (functions 17-19)

With this function you can set the differential (the difference between switching on and switching off temperature) for each section. This can be set between 1 and 10 K.

**Night offset** (function 20)

With this function the night offset can be set between 0 and 5 K and there is always a raising of temperature with regard to the day setting.

For example: With a set point of - 4 °C and an offset of 2 K, the night switching off temperature is raised to - 2 °C.

**Data-log alarm** (function 21)

This alarm function indicates by means of an alarm when the memory is full. This alarm is shown on the interface by LEDs. The memory can be emptied using a PC with the correct Smeva SCU software. No complications arise when the memory is full: the oldest information is then overwritten with new data.

**Function test** (function 22)

The function test is an inspection of the functioning of the control itself. If 'function test' is set to "yes", the control itself controls the operation of the LEDs. Then the control asks to press once on every key, this to inspect the connection of the keys and the print. The relay is then tested. The different relays can be energised by repeatedly pressing "UP". Finally the control inspects the relays and the analog outputs. Between every inspection one has to press the "PRG" key.

**Last error** (functions 23-28)

These 6 functions (23-28) show in the form of a code the last 6 errors identified by the control. This code is given numerically with date and time. The next 4 errors can be shown:

- E 1,2,3,4,5,6,7,8,9 = An error has been identified in one of the maximum 9 sensors. See paragraph 9.2 for an explanation of the various sensors. There could be a kink in the cable of the sensor or the connector could have been detached.
- HI 1,2,3 = The temperature in the section in question is too high according to the settings of the alarm menu. Maybe the upper temperature limit is adjusted too low.
- LO 1,2,3 = The temperature in the section in question is too low according to the settings of the alarm menu. Maybe the lower temperature limit is adjusted too high.
- EE = An error has been identified in the settings. The control has to be replaced.

Example: 16:00 22-05 E2: At 16:00 hours on May 22, an error is identified in sensor 2

**Serial number** (function 29)

This indicates the serial number of the control panel.

**Software version** (function 30)

This indicates the software version.

**IP change 1,2,3** (function 31-33)

This stores the data of the last 3 changes in the user and service menu.

**Start cool 1,2,3** (functions 34, 36, 38)

This function indicates the number of times switched on/off in the last 24 hours. This function can be used as an aid when tracing a fault in a showcase.

**Time cool 1,2,3** (functions 35, 37, 39)

This function indicates the total cooling time over the last 24 hours per section; it indicates the operating time percentage and is therefore an aid when tracing a fault in the cooling device.

**Network number** (function 90)

With this function, the network number can be set that corresponds to the control unit in question. In larger stores, several control units can be called up remotely via a P.C. Each unit thus has its own network number for calling up the correct unit.

**Log interval** (function 91)

With this function, it is possible to set the number of minutes' interval at which the control unit stores the log.

## 8 DEFROST MENU

### 8.1 Selecting defrost menu

The defrost menu can be selected as follows. If the **"PRG"** and **"DOWN"** keys are pressed at the same time, after 5 seconds 'FUNCTIONS MENU' appears on the display. By pressing the **"UP"** key once, 'DEFROST MENU' appears in the display. This menu can be activated by pressing the **"SET"** key. The first start time for the defrosting is now shown on the display. You can now go through the menu by pressing the **"UP"** or **"DOWN"** key. The functions you see here are dealt with in section 8.2.

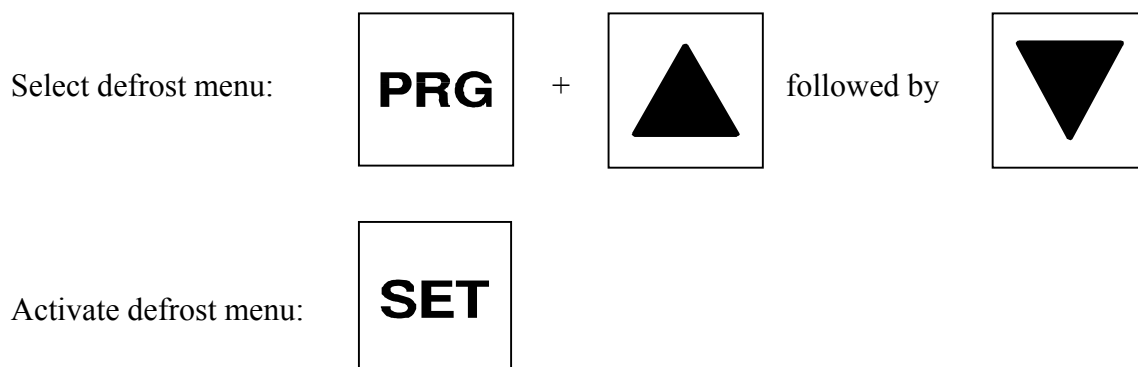

### 8.2 Functions within the defrost menu

**Start defrost 1,2,3,4,5,6** (functions 40, 42, 44, 46, 48, 50)

With these functions you can set the 6 start times of the automatic defrosts. Manual defrosting is also possible, see section 11. If you want less than 6 defrosts per 24 hours, you can "switch off" a start time by pressing "SET" and "DOWN" at the same time until "OFF" appears on the display (this mode appears between 23.59 and 00.00 on the display).

**Maximal defrost time 1,2,3,4,5,6** (functions 41, 43, 45, 47, 49, 51)

With this function you can enter the maximum defrost times (up to a maximum of 3 hours). The defrosting ends when this maximum defrost time is completed or if the defrost end temperature is reached.

**Fan delay after defrost** (function 52, only freezing cell M30!)

With this function you can set the fan delay after defrosting to a maximum of 1 hour.

**Electric defrost** (function 53, only freezing cell M30!)

With this function you can select between defrosting the freezing cell electrically or in a natural manner. In the case of electric defrosting, the humidification relay is used, as there is no humidification in a freezing cell.

**Fans at defrost** (function 86, walk-in freezer M30 only!)

With this function, it is possible to set whether the fans do (yes) or do not (no) stay on during defrost.

**Display fixed at defrost** (function 54)

With this you can select whether the read out section temperatures are "maintained" on the display during defrosting (yes) or whether the read out actual section temperatures (no) are shown increase on the display.

**End of defrost section 1,2,3** (functions 55-57)

With this function the defrost end temperatures can be set for the 3 cooling sections. The defrosting ends when this temperature is reached or when the maximum defrost time is completed. LED 19 will be lit during defrosting and will flash for 10 minutes after defrosting.

## 9 CALIBRATION MENU

### 9.1 Selecting calibration menu

The calibration menu can be selected as follows. If the **"PRG"** and **"DOWN"** keys are pressed at the same time, after 5 seconds 'FUNCTIONS MENU' will appear on the display. By pressing the **"UP"** key twice, 'CALIBRATION MENU' appears on the display. This menu can be activated by pressing the **"SET"** key. Adjustment sensor 1 appears on the display. You can then go through the menu by pressing the **"UP"** or **"DOWN"** key. The functions you see here are dealt with in section 9.2.

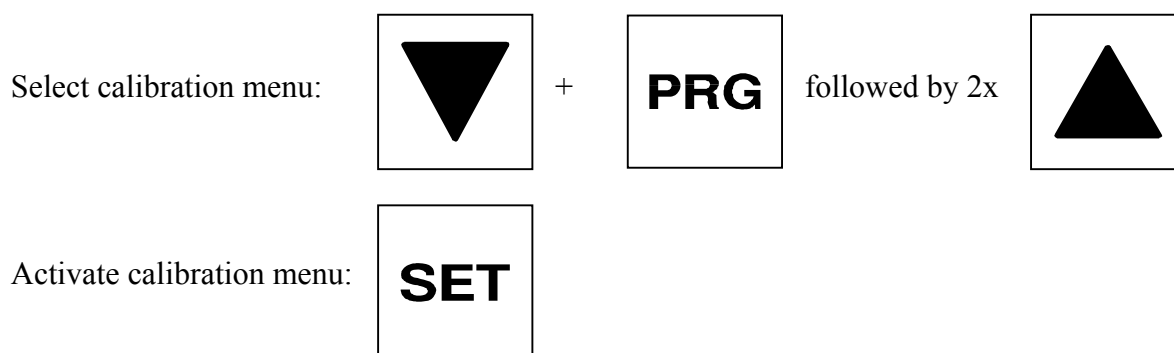

### 9.2 Functions within the calibration menu

**Adjustments sensor 1,2,3,4,5,6,7,8,9** (functions 58-66)

With these functions you can calibrate the readout of the sensors. Each sensor has a calibration indication (at the connections). If this is greater than 0.3 K, it should be calibrated.

If the temperature readout of the sensor in question is then still not correct, a 1% accurate resistor of 815  $\Omega$  should be connected at the sensor input and the common input. The display should then read 0 degrees Celsius. For a rear view of the control unit see enclosure 1A and for how to calibrate the sensors see enclosure 1E.

sensor 1 in display = input S11 of control (intake temp. for the evaporator coil in section 1)

sensor 2 in display = input S12 of control (outlet temp. under the evaporator coil in section 1)

sensor 3 in display = input S13 of control (defrost end temp. or current evaporator temp. in section 1)

sensor 4 in display = input S21 of control (intake temp. for the evaporator coil in section 2)

sensor 5 in display = input S22 of control (outlet temp. under the evaporator coil in section 2)

sensor 6 in display = input S23 of control (defrost end temp. or current evaporator temp. in section 2)

sensor 7 in display = input S31 of control (intake temp. for the evaporator coil in section 3)

sensor 8 in display = input S32 of control (outlet temp. under the evaporator coil in section 3)

sensor 9 in display = input S33 of control (defrost end temp. or current evaporator temp. in section 3)

**Display offset section 1,2,3** (functions 67-69)

With these functions the display value for the three cooling sections can be changed several degrees (-10, 9.9 .... +10 K).

## 10 ALARM MENU

### 10.1 Select alarm menu

The alarm menu can be selected as follows. If the "**PRG**" and "**DOWN**" keys are pressed at the same time, after 5 seconds 'FUNCTIONS MENU' appears on the display. By pressing the "UP" key 3 times, 'ALARM MENU' will appear on the display. To activate this menu it must be selected with the "**SET**" key. 'Delay alarm 1' now appears on the display. You can now go through the menu by pressing the "UP" or "**DOWN**" key. The functions you see here are dealt with in section 10.2.

worden in paragraaf 10.2 behandeld.

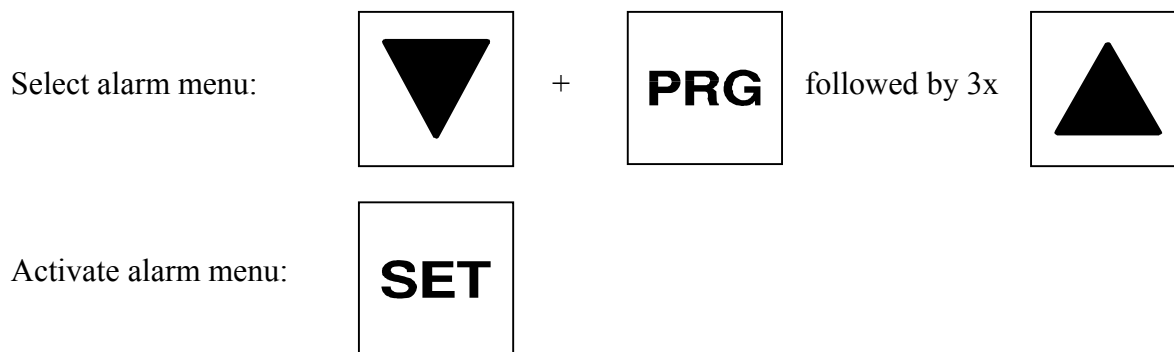

### 10.2 Functions within the alarm menu

#### Delay alarm 1,2,3 (functions 70-72)

With these functions the reaction delays of the alarm in sections 1, 2 and 3 can be set up to a maximum of 4 hours.

#### HI alarm 1,2,3 (functions 73-75)

With these functions the alarm for too high temperatures in cooling sections 1, 2 and 3 can be switched on and off.

**HI temperature 1,2,3** (functions 76-78)

With these functions the upper limit temperatures of the alarm for the cooling sections can be set, provided they are at least 5 degrees Celsius higher than the lower limit temperatures.

ID. This means air temperature.

**LO alarm 1,2,3** (functions 79-81)

With these functions the alarm for too low temperatures in cooling sections 1,2 and 3 can be switched on and off.

**LO temperature 1,2,3** (functions 82-84)

With these functions the lower limit temperatures of the alarm for the cooling sections can be set, provided they are at least 5 degrees Celsius lower than the upper limit temperatures.

ID. This means air temperature.

**11 OTHER FUNCTIONS****11.1 Manual defrosting**

Manual defrosting is also possible in addition to the defrosts set in the menu. This can be started by pressing the "SET" and "DOWN" key at the same time:

Select manual defrosting:



The defrost lamp (LED 18) then lights up. Manual defrosting ends when the defrost end temperature is reached or when the maximum defrosting time of 3 hours is completed.

**11.2 Additional connections**

Three additional displays can be connected to the control panel, for the temperature readout on the customer side (for the SCU 535). An emergency power supply in the form of a battery can also be connected to the control panel so that the data for the log functions are stored in the circular memory if there is a power cut. In this case "power drop" appears on the display. By pressing the "SET" key, this message is deleted from the display:



The battery is also automatically recharged by the control when the voltage (mains power) is restored.

## 12 ENCLOSURES

### Enclosure 1A: Back view of control

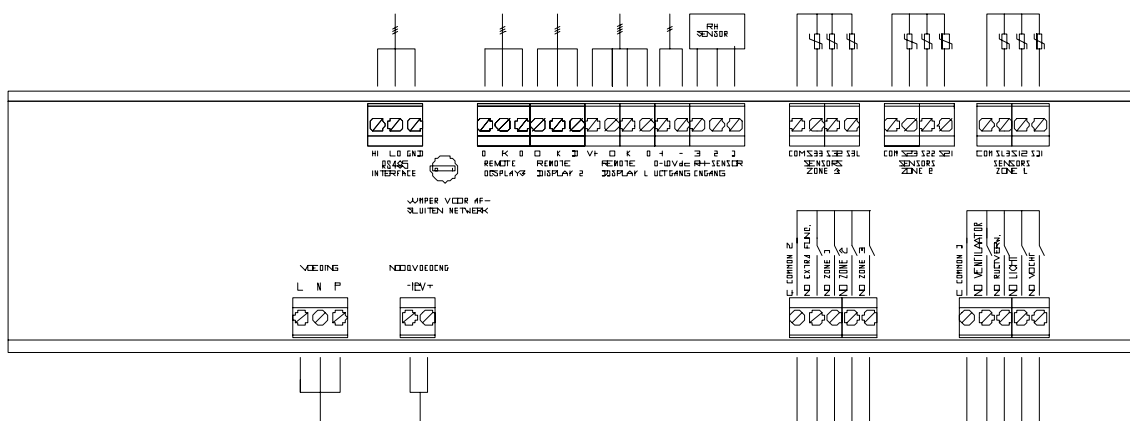

### Connections:

- Sensors : 9 x KTY81-1 Sensors  
 : RH Sensor 0-1 Vdc signal, 12 Vdc
- Relais : Moist (NO, 250 Vac / 5A inductif, 8A not inductif)  
 : Light (NO, 250 Vac / 5A inductif, 8A not inductif)  
 : Window heating (NO, 250 Vac / 5A inductif, 8A not inductif)  
 : Fan (NO, 250 Vac / 5A inductif, 8A not inductif)  
 : Extra function (NO, 250 Vac / 5A inductif, 8A not inductif)  
 : Cooling section 1 (NO, 250 Vac / 5A inductif, 8A not inductif)  
 : Cooling section 2 (NO, 250 Vac / 5A inductif, 8A not inductif)  
 : Cooling section 3 (NO, 250 Vac / 5A inductif, 8A not inductif)
- Analoge Ausgang: 0-10 Vdc Moist capacity (0 - 100%)
- Kommunikation : RS485  
 : 3 remote display units

### Enclosure 1B: Replacing the fuse

When the functions of the control are out of order, although the 220 Volt is adapted, most probably the fuse is burnt out. The fuse can be replaced by removing the rear coverplate of the control box. The fuse is 250 V, 315 mA laxly.

**Enclosure 1C: Jumper for the end of a network**

When the control unit is connected to the end of a communication network, a jumper must be placed at the rear of the control unit. Where a control unit is not connected to the end of a communication network, this jumper must be removed.

**Enclosure 1D: Technical specifications**

- Power supply : 230 Vac / 50 - 60 Hz. (-10% / +5%) or 115 Vac/ 50 - 60 Hz. (-10% / 5%)
- Emergency power supply : 12 V DC (option)
- Range : -40 / +30 °C per 1°C
- : 10 / 100 % RH
- Function temperature : -20 / +40 °C
- Storage temperature : -20 / +60 °C
- Functioning area RH : 10 - 90% RH not condensing
- Accuracy : +/- 0.5 % of the range
- House : Aluminium profile
- Dimensions : 300 x 72 x 71 mm (b x h x d)
- Front : Polycarbonate

**Security:**

This control is in accordance with the CE- marking.

**Enclosure 1E: Calibrating the sensors**

The sensors can be calibrated by putting them in a glass of water with melting ice in it. The temperature of the water is 0 °C. The resistance of the sensor must be 817 Ω then, as can be seen in the table below.

T amb.	Resistance
-55	495
-50	514
-40	568
-30	625
-20	686
-10	750
0	817
10	887
20	961
25	1000
30	1039
40	1120
50	1205
60	1295

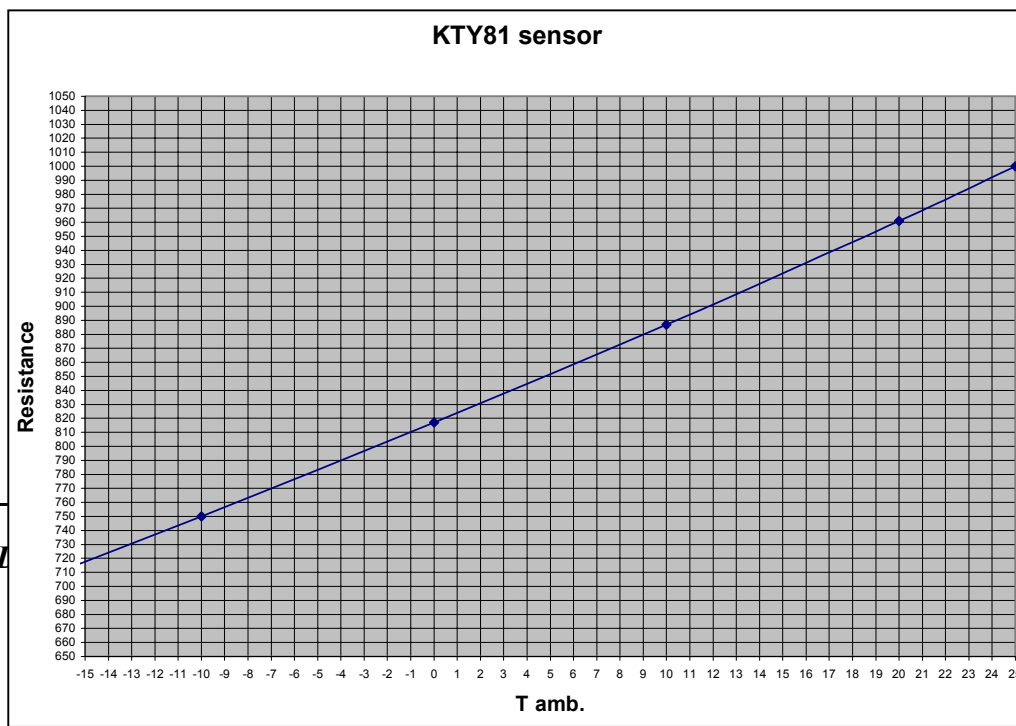

70	1390
80	1489
90	1591
100	1696
110	1804
120	1915
130	2017
140	2120
150	2225

**Enclosure 2: Default values SCU 515/535**

The default values for each type of cooling unit are given in the following pages as pre-programmed as standard.