



SERVICE AND INSTALLATION INSTRUCTIONS

KEEP THIS BOOKLET FOR FUTURE REFERENCE

BMD & BSD SERIES

REVISED 9-8-00

BARKER COMPANY

P.O. Box 478

703 Franklin Street

Keosauqua, IA 52565

Tel: 319-293-3777

Fax: 319-293-3776

www.barkercompany.com

UK Agent: Phoenix Retail Services Ltd

Fryers Farm Office, Fryers Farm Lane, Lane End,

High Wycombe HP14 3NP

Tel: 01494-880200 Fax: 01494-881204

sales@phoenixretail.com www.phoenixretail.com

TABLE OF CONTENTS

GENERAL INFORMATION

Case Descriptions-----	3
Shipping Information-----	4
Case Sections and Mechanical Views-	
BSD-----	5
BMD-----	6

INSTALLATION INSTRUCTIONS

Location-----	7
Crate Removal-----	7
Drain, Electrical and Refrigeration ----	
Connections-----	8
Humidifier System-----	8
Joining Lineups-----	8
Leveling-----	8
Glass Adjustment-----	9
Optional Shelving-----	9

REFRIGERATION INFORMATION

Case Operation-----	11
Typical Component Settings-----	12
Refrigeration Loads-----	12

MAINTENANCE INFORMATION

Cleaning	13
Light Bulb Replacement	13
Seafood Application	14
Load Limits	15

SERVICE

Evaporator Coil Area	16
----------------------	----

**IMPORTANT
KEEP FOR FUTURE REFERENCE**

GENERAL INFORMATION

This booklet contains information on:

BSD SERIES

Euro Style, Single Deck Service Deli Merchandiser

BMD SERIES

Euro Style, Service Deli Merchandiser With Optional Mezzanine Shelves

The BMD and BSD Series have been approved for the following standards:



FOR ADDITIONAL COPIES OF THIS BOOKLET OR FOR MORE INFORMATION CONTACT:

**BARKER COMPANY
SERVICE DEPARTMENT**

P.O. BOX 478

703 FRANKLIN STREET

KEOSAUQUA, IOWA 52565

319-293-377 PHONE

319-293-3776 FAX

service@barkercompany.com

In the UK contact:

Phoenix Retail Services Ltd

Fryers Farm Office, Fryers Farm Lane, Lane End,

High Wycombe HP14 3NP

Tel: 01494-880200 Fax: 01494-881204

sales@phoenixretail.com www.phoenixretail.com

IMPORTANT
FOR YOUR PROTECTION PLEASE READ AND OBSERVE THE
FOLLOWING INSTRUCTIONS:

Transportation companies assume all liability from the time a shipment is received by them until the time it is delivered to the consumer. Our liability ceases at the time of shipment.

All shipments leaving our plant have been carefully inspected. If a shipment arrives with the crating or packaging damaged, have the carrier note the condition on the receipt. Check as soon as possible for concealed damage.

If it is found that the shipment has been damaged in transit, please **DO NOT** return it to us, but notify and file a claim with the carrier at once. **FAILURE TO FOLLOW THIS PROCEDURE WILL RESULT IN REFUSAL BY THE CARRIER TO HONOR ANY CLAIMS WITH A CONSEQUENT LOSS TO THE CONSUMER.**

If a UPS shipment has been damaged, retain the damaged material and the carton and notify us at once. **WE** will file a claim.

GOODS SHOULD NOT BE RETURNED FOR CREDIT UNLESS AUTHORIZED BY OUR SALES DEPARTMENT.

BSD SERIES

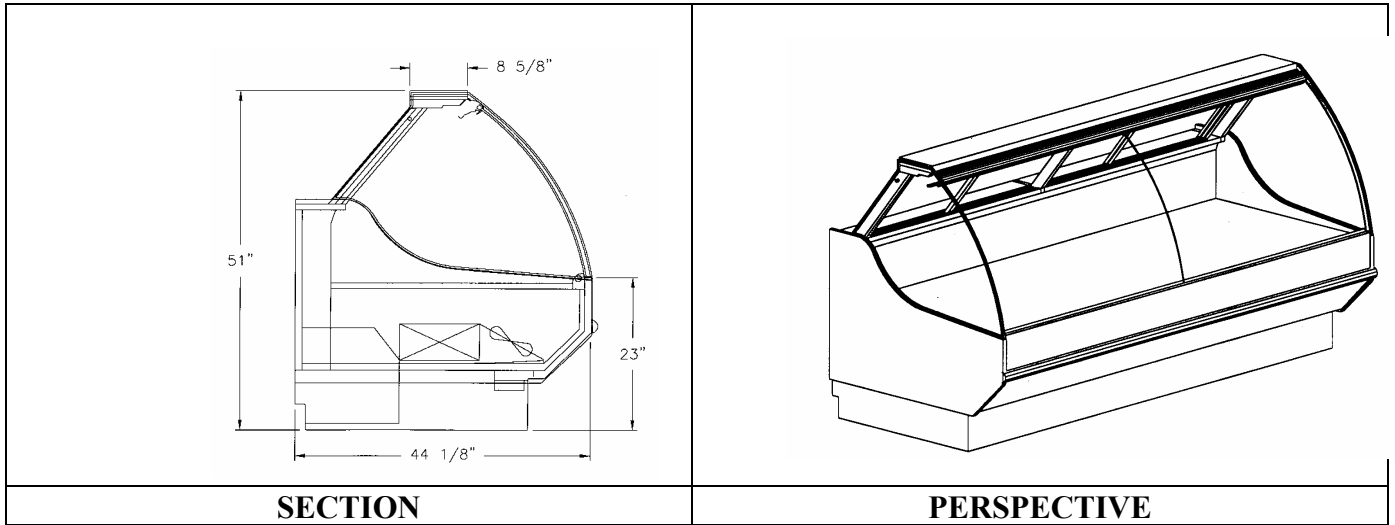

Remote Mechanical Views

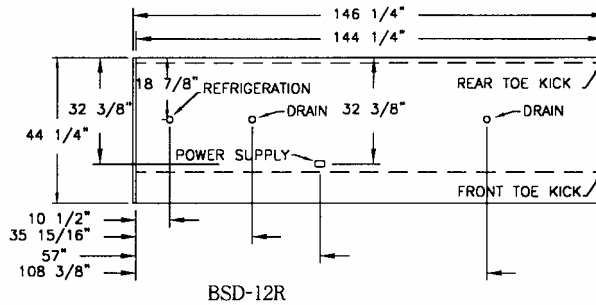
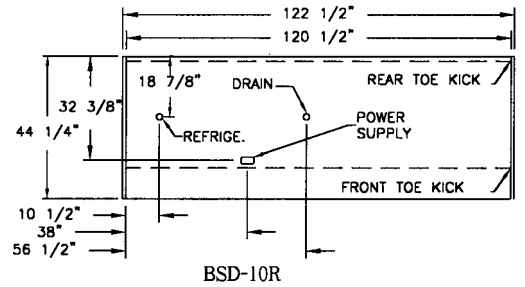
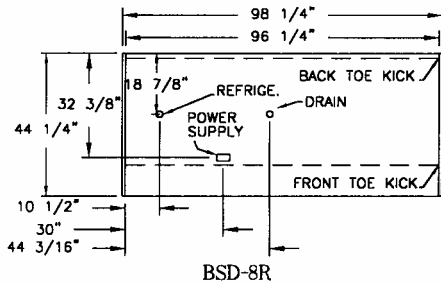
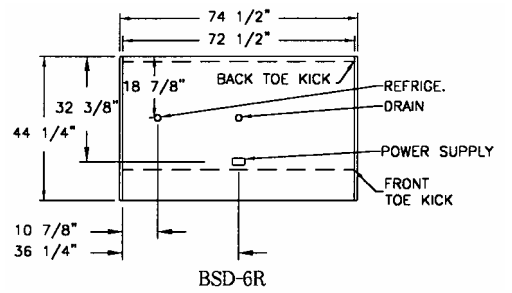
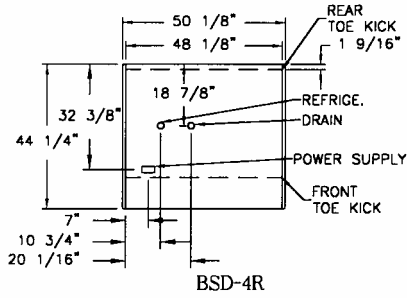

BMD SERIES

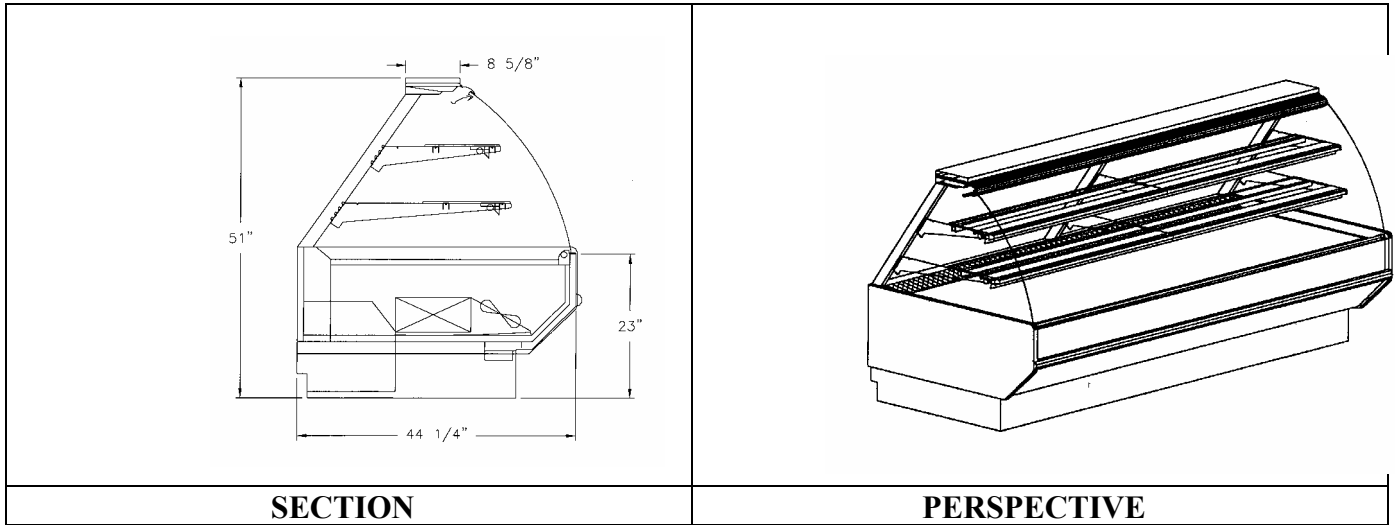

Remote Mechanical Views

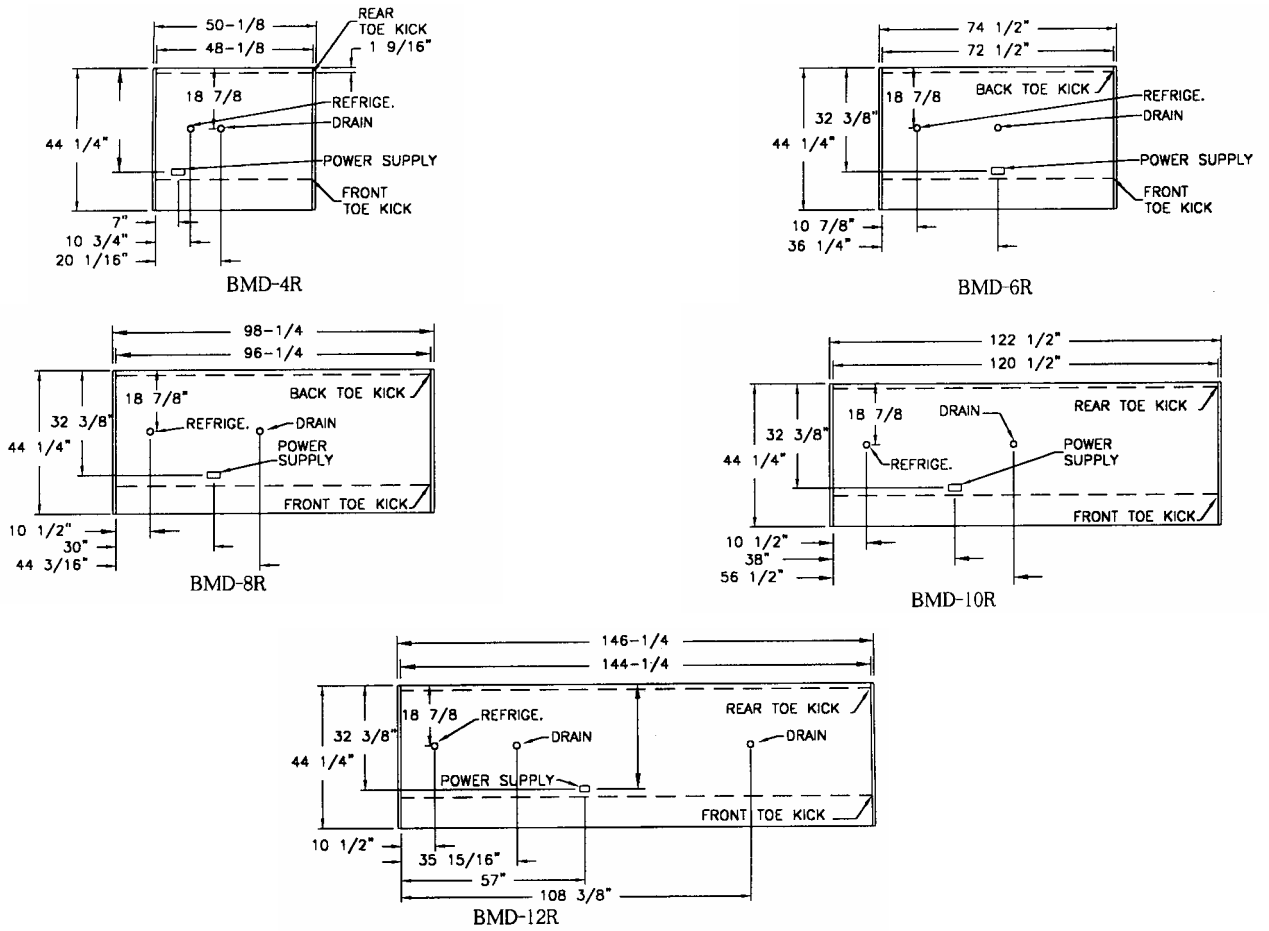

INSTALLATION INSTRUCTIONS

LOCATION

This refrigerated display case has been designed for displaying and the storage of perishable food product. It is engineered for air-conditioned stores with a maximum ambient of 24°C and 50% relative humidity.

When selecting the location for placement of this case, avoid the following conditions:

1. Excessive heat
 - A. Windows
 - B. Sun
 - C. Flood lamps 8 feet or less from the product
 - D. Other heat sources.

CRATE REMOVAL

Move case as close as possible to its location. Remove all crating and shipping braces above the shipping pallet. Loosen the plastic dust cover from the pallet, but leave cover over the case to protect it while removing the case from the pallet. Carefully, lift case up and off the pallet. Remove dust cover. **Installation hardware ships in an installation packet located inside the case.**

COMPRESSOR

NOTE - The 6', 8', 10 and 12' Self-Contained cases are equipped with a shipping block under the compressor. This block must be removed upon installation. **Failure to remove the block will result in excessive noise, refrigerant leaks and will void warranty protection.** Loosen all four nuts on the compressor hold down screws. Lift or pry the compressor up and remove the shipping block. **Do not** retighten screws as the compressor should be left free to float on the spring mounts.

CASE EXTERIOR LOADING

These cases are not designed for excessive external weight. **DO NOT WALK ON THE TOP OF THE CASE.** Walking on top of cases could cause personal injury and damage to the case.

LEVELING

To ensure proper operation of the refrigeration system and drainage of the condensate, **this case must be level.** Use a carpenter level to level front to back and side to side. Shim as necessary.

JOINING LINEUPS

1. **Begin all lineups leveling from the highest point of the store floor.**
2. Remove front and rear toe kicks by removing screws on all sides. Set and level first case.
3. Level second case to first case and seal with a good grade silicone on all edges of each case.
4. Line up bottom bolt holes in lower toe kicks (bolts for these are located in the installation packet inside the case) and line up bolt stud located in top rear strut with bolt hole in adjoining case. Slide cases together. Insert lower bolts and place nuts on bolts. Tighten.
5. A top joining plate is also located in the canopy of the case. Ensure that case is properly leveled so that the screw holes in this plate align over the screw holes in the adjoining case. Shim as necessary.

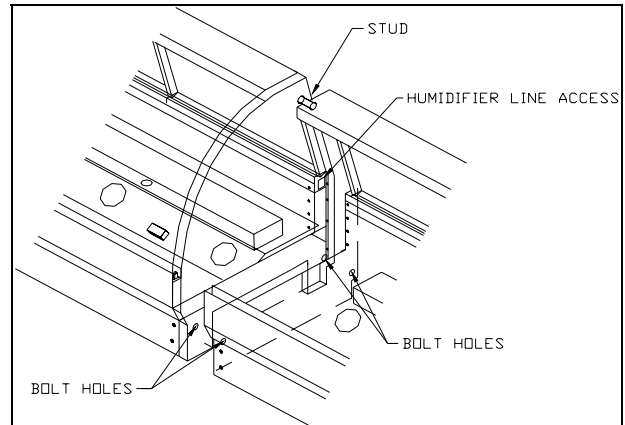

THE FRONT OF THE CASES MUST BE FLUSH.

6. Screw in top plate and ensure all bolts are fastened tightly.
7. Seal all seams. Use metal U-channel located inside case to seal and cover where interior case beds join.

DRAIN, ELECTRICAL, AND REFRIGERATION CONNECTIONS FOR ALL REMOTE CASES

1. Connect PVC drains to existing floor drains. Provide as much downhill slope as possible and avoid long runs of drain lines. Do not install condensate drains in contact with non-insulated suction lines in order to prevent condensate from freezing (See mechanical plans and table for drain locations). **All drains must be trapped.**
2. Electrical connections are made through the power supply box of each case, which can be accessed from the front toe kick. (see mechanical plans). Voltage requirements and component amperes can be found in the electrical section of this manual, but always check the data tag located on the exterior of the case. **Case must be grounded.**
3. Refrigeration connections will be made through the refrigeration stub up (see mechanical plans and table for each case). See refrigeration information section for case loads and recommended settings. Refrigeration lines may be headed together for all cases in a lineup, if desired, by running lines through the access area under the case. Seal all access holes to prevent recirculation. **All lines must be correctly sized.**

For proper refrigeration performance, **PRODUCT MUST NOT BE PLACED IN A POSITION WHERE IT MAY AFFECT THE AIR CURTAIN.** Air discharge and return air vents must remain unobstructed.

HUMIDIFIER SYSTEM

This optional feature is installed at the factory. Initial hook-up is as follows:

1. Read installation/service guide, which accompanies unit.
2. If connecting a lineup, which shares a common control system, connect companion case discharge lines.
3. For all cases, connect water supply. **Note: It is recommended that a pre-filter be added to the water supply.**
4. Check for leaks.
5. Adjust water pressure as needed. See manufacturers installation guide for further information.

GLASS ADJUSTMENT

Lift Glass is installed at the factory with the case perfectly level, if adjustments need to be made to align the glass first check to insure the case was properly leveled during installation.

Note: This is a 2-person operation. One person must hold the glass at all times.

1. Lift the glass to its highest position as shown in drawing to the right.
2. Loosen allen screws. See profile below.
3. Starting at the right side, tap the wedge with a #2 standard screwdriver. Repeat procedure on the left side. Continue working right to left until the wedge recesses into the aluminum extrusion. **Extreme care must be taken not to tap the wedge too hard.**

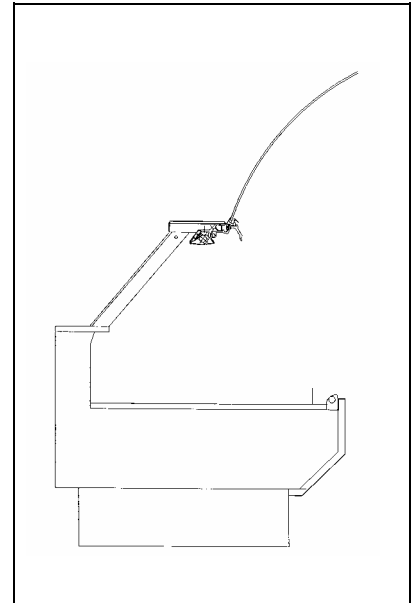

PROFILE OF GLASS CLAMP

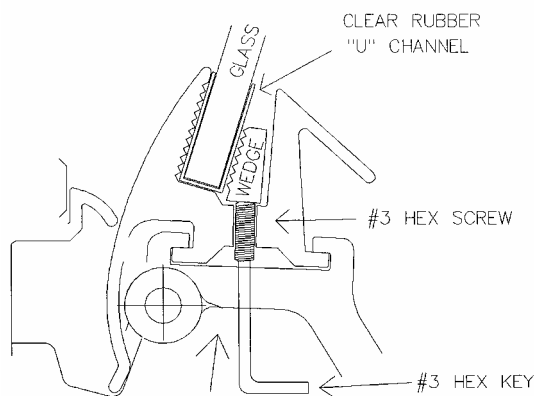

AS THE HEX SCREW IS TURNED, IT FORCES THE SOLID ALUMINUM WEDGE PIECE UP AGAINST THE CLEAR RUBBER "U" CHANNEL AND HOLDS THE GLASS FIRMLY IN PLACE.

4. Slide the glass right or left as needed.
5. Tighten the right allen screw while holding the left side of the glass firmly. Be careful to keep the glass level.
6. Tighten the remaining allen screws.
7. Lower glass into position. Repeat as necessary until glass is completely level.

Note: the entire glass clamp can be moved by loosening the allen screws that are located in the glass clamp hinges.

DOORS

Rear load doors are shipped inside the case. Push top of doors all the way into top door tracks. Push bottom of door over bottom door tracks and lower over tracks. Doors are labeled inside and outside for easy installation.

OPTIONAL SHELVING

Shelves are shipped separately. To place shelving, hold shelf straight and fit brackets straight into channel. Place shelf directly above light outlet. Plug in light making certain the plug is fully engaged. All cases with shelf lights are equipped with an interlocking plug system. **For shelf lights to work plug must be fully engaged**

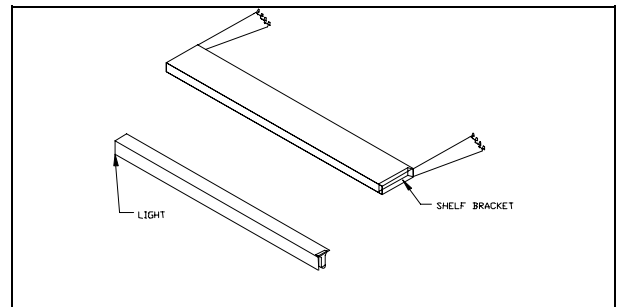

INSTALLATION CHECKLIST

Before supplying electrical power and starting case check the following:

1. Compressor Area (For Self-contained cases).
Remove shipping block on units with semi-hermetic compressors.
Check location of controls.
2. Evaporator Area.
Check to ensure evaporator fan pressure plates are secure and in proper position
[Note; hinged portion of pressure plates are secured for shipping with mounting screws. Screws do not have to be removed for case operation but must be removed to use hinge.]
4. Lighting System.
Check to ensure male plugs are completely inserted in female sockets and that all lamps are securely seated in light fixture.
3. Case Leveling
Visually check case. If lift glass is out of adjustment or case looks out of square, use a carpenter's level and shim as needed.

After supplying power to the case and starting unit:

1. Check to ensure all fans are operational.
2. Check all lights.
3. Check case temperature and adjust thermostat as needed. See refrigeration section of this manual for case suggested settings.

REFRIGERATION INFORMATION

CASE OPERATION FOR ALL SELF CONTAINED UNITS

Refrigeration

The refrigeration in this case is thermostatically controlled. The case refrigerates until the cut out point on the thermostat is reached. The thermostat opens, cutting power to the liquid line solenoid. The compressor continues to run, the system pumps down causing the pressure switch to open, cutting power to the compressor. Note: Some cases may be ordered with EPR valves to control case temperature. For proper refrigeration performance, **product must not be placed in a position where it may affect the air curtain.**

Defrost

This case is equipped with an **off cycle** defrost system. The timer cuts the power to the liquid solenoid. The unit stays in off cycle defrost until the defrost timer re-energizes the liquid solenoid. **Note: The evaporator fan runs continuously.**

TYPICAL COMPONENT SETTINGS

- | | | | | |
|-----------------------------------|------|------------------------------------|-----------------------------|--|
| 1. Thermostat cut out | | 2.2-2.3°C, 2°C differential | | |
| 2. Defrost termination thermostat | | 7°C | | |
| 3. CRO valve | R-22 | 3.86kg/cm ² | | |
| | 404A | 5.3kg/cm ² | | |
| | 134A | N/A | | |
| 4. TXV | | 5°C Superheat | | |
| 5. Pressure switch | R-22 | Low – 1.4 - 4.22kg/cm ² | High – 24kg/cm ² | |
| | 404A | Low – 1.4 – 4.9kg/cm ² | High – | |
| | 134A | Low - .5 – 2.1kg/cm ² | High – | |
- 15.8kg/cm²

Note: The above settings are approximate and will vary slightly with product load, lighting, store ambient conditions etc. Evaporator fans run constantly.

REFRIGERATION LOAD

BLOWER COIL

GRAVITY COIL

Application	Evap Temp					
Fish	+20°F					
Meat	+15°F					
Deli	+18°F					
Model	BTU/Lin. Ft.	Evap. Temp.	Off Cycle Defrost	BTU/Lin. Ft.	Evap. Temp	Off Cycle Defrost
BSD-4	450	-6.7°C	20 ³ /4 hr.	425	-9.4°C	90 ³ /24 hr.
BSD-6	450	-6.7°C	20 ³ /4 hr.	425	-9.4°C	90 ³ /24 hr.
BSD-8	450	-6.7°C	20 ³ /4 hr.	425	-9.4°C	90 ³ /24 hr.
BSD-10	450	-6.7°C	20 ³ /4 hr.	425	-9.4°C	90 ³ /24 hr.
BSD-12	450	-6.7°C	20 ³ /4 hr.	425	-9.4°C	90 ³ /24 hr.
BMD-4	650	-6.7°C	20 ³ /4 hr.	425	-9.4°C	90 ³ /24 hr.
BMD-6	650	-6.7°C	20 ³ /4hr.	425	-9.4°C °	90 ³ /24 hr.
BMD-8	650	-6.7°C	20 ³ /4 hr.	425	-9.4°C	90 ³ /24 hr.
BMD-10	650	-6.7°C	20 ³ /4 hr.	425	-9.4°C	90 ³ /24 hr.
BMD-12	650	-6.7°C	20 ³ /4 hr.	425	-9.4°C	90 ³ /24 hr.

ELECTRONIC THERMOSTAT

The electronic thermostat is located behind the case's rear toe kick . The thermostat is equipped with a liquid crystal display providing a constant readout of the sensed temperature.

NOTE: The LCD display will be blank during defrost. A touch keypad that allows the users to select the set point temperature, differential and the heating /cooling modes.

Programming Steps for the ETC, Electronic Temperature Control

- STEP 1.** Press the set key once to access the Fahrenheit/Celsius mode. The display will display either **F** degrees Fahrenheit or **C** for degrees Celsius. Press the **up** arrow or the **down** arrow so the display indicates **F**.
- STEP 2.** Press the set key again to gain access to the setpoint. The LCD will display the current Setpoint and the **S1** will be blinking. Press the **up** arrow to increase or the **down** arrow to decrease the temperature setting.
- STEP 3.** Press the set key again to gain access to the differential. The LCD will display the current differential and the **DIF 1** will be blinking. This should be set at 3 degrees.
- STEP 4.** Press the set key again to gain access to the cooling or heating mode. The LCD will display the current mode. Press either the **up** arrow or the **down** arrow to set the display in the **C1**, cooling mode
- STEP 5.** **Press the set key once more and the programming is complete.**

STEP	DISPLAY INDICATION	DESCRIPTION
1.	F or C	Fahrenheit or Celsius Scale

2.	S1 (blinking)	Setpoint Temperature
3.	DIF (blinking)	Differential Temperature
4	C1/H1	Cooling or Heating Mode

MAINTENANCE INFORMATION

CLEANING

Case Exterior

Clean surfaces frequently with warm water and mild detergent. **Do not** use strong alkali solutions, steel wool, or abrasive cleansers. Be careful of any electrical outlets located on the rear of the case.

Case Interior

All shelving and lower deck can be removed for cleaning (See installation instructions for removing and setting shelving). Check to make sure the case drain(s) are not clogged. Clean interior with warm water and a mild detergent. A sanitizer should be used after washing to eliminate bacteria. Rinse thoroughly being careful not to flood drain system. Avoid spraying water directly into electrical connections. **DO NOT USE A HIGH PRESSURE WATER HOSE. MAKE SURE FANS ARE SHUT OFF WHEN CLEANING THE INTERIOR OF THE CASE.**

FrontLift Glass

Use any good quality glass cleaner. Wipe glass dry to avoid streaking. Use soapy water and a cloth to remove difficult smudges. Rubbing alcohol may also be used on soils that are difficult to remove.

Evaporator Coil

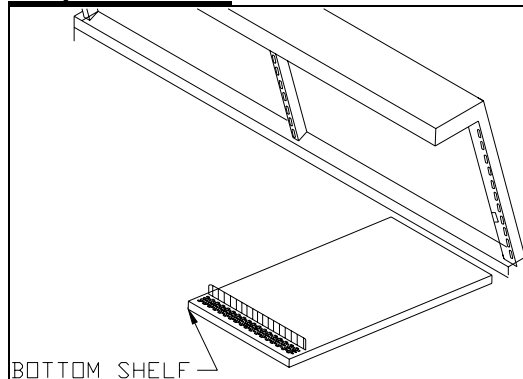

1. Remove bottom deck by lifting front of shelf 30° and pulling out of channel.
2. Clean evaporator coil as needed.

Condenser Coil

Failure to clean coils will void warranty. Clean condenser coil every three months or as needed with a whisk broom or vacuum. **Disconnect power when servicing. Fins on condenser coil are sharp!**

Condensate Heater

(Evap-O-Way)

Add one teaspoon of scale remover or white vinegar to condensate heater pan once every three months or as needed. Heater is designed for 75° and 50% relative humidity. The condensate pan may overflow if design limits are exceeded.

SEAFOOD APPLICATION

Plexiglas should be removed for cleaning. Reinstall plexiglas by placing in front of case. Ice will hold it in place. **Plexiglas must be in place to keep ice out of air screen.**

LIGHT REPLACEMENT

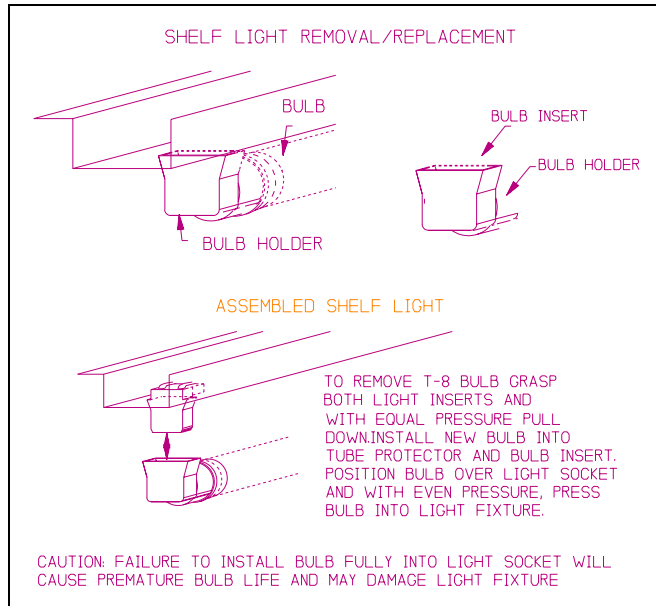

The fluorescent lights in this case are furnished with plastic safety shields and end caps.

When replacing fluorescent lamps, be certain to reinstall safety shield and caps. **See Illustration**

If the bulb is not fully seated the lights will not operate. **Be sure bulbs are fully seated.**

The light switch is mounted on the rear of the case. See mechanical drawing for ballast box location.

LOAD LIMITS

DO NOT place product in merchandisers until all refrigeration controls have been adjusted and are at the proper operating temperature.

DO NOT over load shelving or place product where it may affect the air curtain. See drawing. ----- indicates Load Limit.

Product placed above dotted line will interfere with air flow.

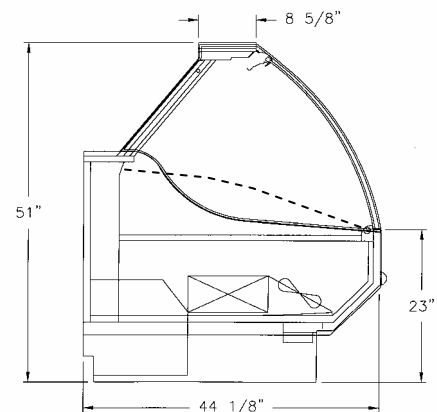

SERVICE

**DISCONNECT THE ELECTRICAL POWER
WHEN SERVICING OR REPLACING ANY
ELECTRICAL COMPONENT.**

EVAPORATOR COIL AREA

To access Evaporator Coil area:

Remove bottom shelf by lifting up and out.

